



E-Star Power Development Co., Ltd. (E-STAR)  
 1F., No.40, Juren Ln., Sec. 2, Sanmin Rd., Banciao Dist., New Taipei City  
 22069, Taiwan (R.O.C.)  
 Phone : 886-2-2957 5580 Fax : 886-2-2957 7473

**65W Open Frame type Triple output power supply > PT-65**



■ Features :

- Universal AC input/Full range
- Low leakage current<0.5mA
- Protections: Short circuit / Overload / Over voltage
- Cooling by free air convection
- 100% full load burn-in test
- Fixed switching frequency at 65KHz
- 2 years warranty



**SPECIFICATION**

MODEL	PT-65A			PT-65B			PT-65C			PT-65D			
OUTPUT	OUTPUT NUMBER	CH1	CH2	CH3	CH1	CH2	CH3	CH1	CH2	CH3	CH1	CH2	CH3
	DC VOLTAGE	5V	12V	-5V	5V	12V	-12V	5V	15V	-15V	5V	12V	24V
	RATED CURRENT	5.5A	2.5A	0.5A	5.5A	2.5A	0.5A	5.5A	2A	0.5A	4A	2A	1A
	CURRENT RANGE	0.4 ~ 7A	0.2 ~ 3.2A	0 ~ 0.7A	0.4 ~ 7A	0.2 ~ 3.2A	0 ~ 0.7A	0.4 ~ 7A	0.2 ~ 2.6A	0 ~ 0.7A	0.5 ~ 5A	0.2 ~ 4A	0.2 ~ 1.3A
	RATED POWER	60W			63.5W			65W			68W		
	OUTPUT POWER (max.)	Rated output power for convection; 72W with 18CFM min. Forced air											
	RIPPLE & NOISE (max.) Note.2	50mVp-p	120mVp-p	50mVp-p	50mVp-p	120mVp-p	100mVp-p	50mVp-p	120mVp-p	100mVp-p	50mVp-p	100mVp-p	200mVp-p
	VOLTAGE ADJ. RANGE	CH1:4.75 ~ 5.5V											
	VOLTAGE TOLERANCE Note.3	±4.0%	±7.0%	±5.0%	±4.0%	±7.0%	±5.0%	±4.0%	±7.0%	±5.0%	±4.0%	±6.0%	±6.0%
	LINE REGULATION	±1.0%	±2.0%	±1.0%	±1.0%	±2.0%	±1.0%	±1.0%	±2.0%	±1.0%	±1.0%	±2.0%	±3.0%
LOAD REGULATION	±3.0%	±4.0%	±1.0%	±3.0%	±4.0%	±1.0%	±3.0%	±4.0%	±1.0%	±2.0%	±5.0%	±5.0%	
SETUP, RISE TIME	800ms, 20ms at full load												
HOLD UP TIME (Typ.)	60ms at full load												
INPUT	VOLTAGE RANGE	90 ~ 264VAC			127 ~ 370VDC								
	FREQUENCY RANGE	47 ~ 440Hz											
	EFFICIENCY(Typ.)	76%			77%			77%			79%		
	AC CURRENT (Typ.)	1.5A/115VAC			0.9A/230VAC								
	INRUSH CURRENT (Typ.)	COLD START 20A/115VAC			40A/230VAC								
LEAKAGE CURRENT	<0.75mA												
PROTECTION	OVERLOAD	73 ~ 95W rated output power									74.8 ~ 98.6W rated output power		
	OVER VOLTAGE	5.75 ~ 6.75VDC on CH1 Protection type : Hiccup mode, recovers automatically after fault condition is removed.											
ENVIRONMENT	WORKING TEMP.	-10 ~ +60°C (Refer to "Derating Curve")											
	WORKING HUMIDITY	20 ~ 90% RH non-condensing											
	STORAGE TEMP., HUMIDITY	-20 ~ +85°C, 10 ~ 95% RH											
	TEMP. COEFFICIENT	±0.04%/°C (0 ~ 50°C) on +5V output											
	VIBRATION	10 ~ 500Hz, 2G 10min./1cycle, period for 60min. each along X, Y, Z axes											
SAFETY & EMC (Note 4)	SAFETY STANDARDS	UL62368-1, TUV EN62368-1, EAC TP TC 004 approved											
	WITHSTAND VOLTAGE	I/P-O/P:3KVAC I/P-FG:2KVAC O/P-FG:0.5KVAC 1min.											
	ISOLATION RESISTANCE	I/P-O/P, I/P-FG, O/P-FG:100M Ohms / 500VDC / 25°C / 70% RH											
	EMC EMISSION	Compliance to EN55032 (CISPR32) Class B, EN61000-3-2,-3, EAC TP TC 020											
OTHERS	EMC IMMUNITY	Compliance to EN61000-4-2,3,4,5,6,8,11, EN55024, light industry level, criteria A, EAC TP TC 020											
	MTBF	277.2K hrs min. MIL-HDBK-217F (25°C)											
	DIMENSION	127*76*42mm (L*W*H)											
NOTE	PACKING	0.25Kg; 54pcs/15.9Kg/1.28CUFT											
		1. All parameters NOT specially mentioned are measured at 230VAC input, rated load and 25°C of ambient temperature. 2. Ripple & noise are measured at 20MHz of bandwidth by using a 12" twisted pair-wire terminated with a 0.1uf & 47uf parallel capacitor. 3. Tolerance : includes set up tolerance, line regulation and load regulation. 4. The power supply is considered a component which will be installed into a final equipment. All the EMC tests are been executed by mounting the unit on a 360mm*360mm metal plate with 1mm of thickness. The final equipment must be re-confirmed that it still meets EMC directives. For guidance on how to perform these EMC tests, please refer to "EMI testing of component power supplies." 5. Mounting holes M1 and M2 should be grounded for EMI purposes. 6. Heat Sink HS1,HS2 can not be shorted. 7. The ambient temperature derating of 3.5°C/1000m with fanless models and of 5°C/1000m with fan models for operating altitude higher than 2000m(6500ft).											

**65W Open Frame type Triple output power supply > PT-65**

**Mechanical Specification**

Unit:mm

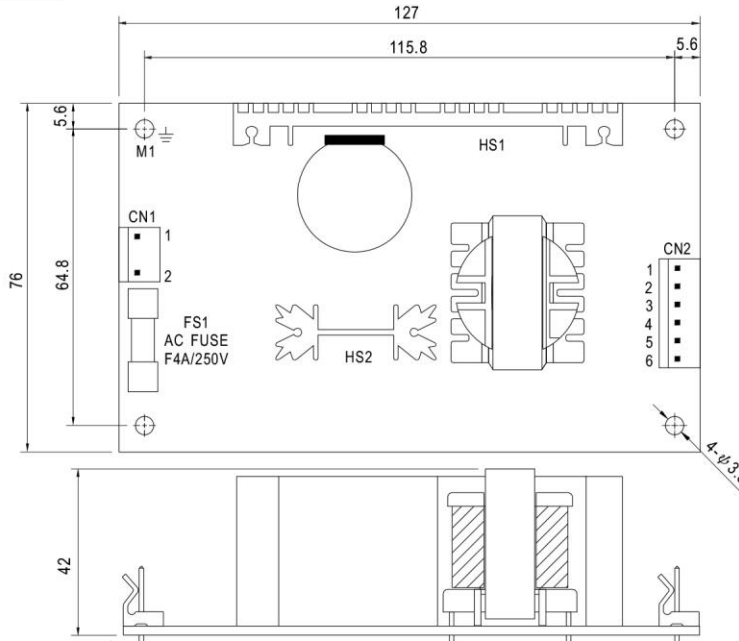

⚠ 1.HS1,HS2 cannot be shorted  
 2.M1 is safety ground

AC Input Connector (CN1) : Molex 5277-02 or equivalent

Pin No.	Assignment	Mating Housing	Terminal
1	AC/N	Molex 5195 or equivalent	Molex 5194 or equivalent
2	AC/L		

⏏ : Grounding Required

DC Output Connector (CN2) : Molex 5273-06 or equivalent

Pin No.	Assignment	Mating Housing	Terminal
1	V2	Molex 5195 or equivalent	Molex 5194 or equivalent
2,3	+5V		
4,5	COM		
6	V3		

※PIN2:+5V PIN3,4,5:COM only for PT-65D

**Block Diagram**

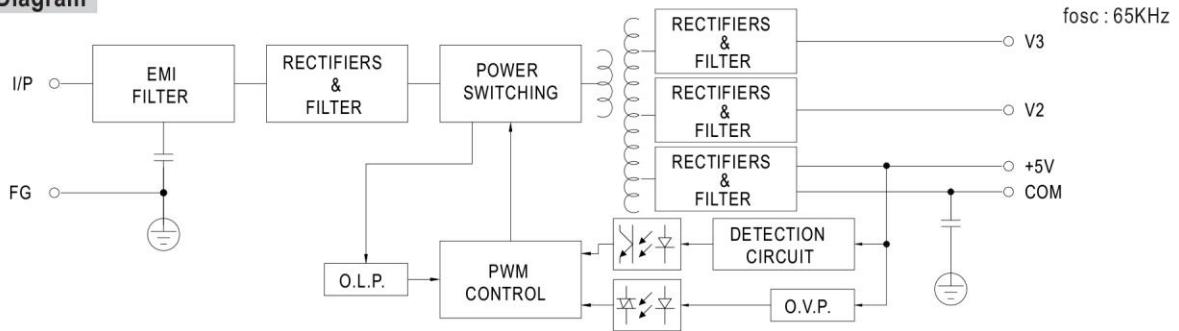

**Derating Curve**

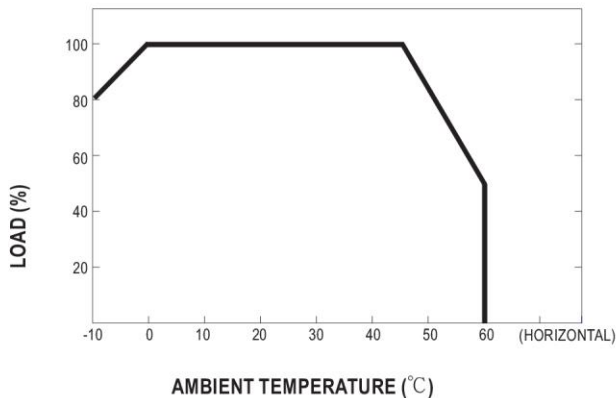

**Output Derating VS Input Voltage**

