



250W Open Frame type Dual output power supply > PID-250



■ Features :

- Universal AC input / Full range
- Isolated output & GND for CH1,CH2
- Built-in active PFC function, PF>0.92
- Protections:Short circuit / Overload / Over voltage / Over temperature
- Remote control for CH1
- Peak load 170% for CH1 within 10 sec.
- Cooling by free air convection
- 100% full load burn-in test
- 3 years warranty



SPECIFICATION

MODEL	PID-250A		PID-250B		PID-250C		PID-250D		
OUTPUT	OUTPUT NUMBER	CH1	CH2	CH1	CH2	CH1	CH2	CH1	CH2
	DC VOLTAGE	12V	5V	24V	5V	36V	5V	48V	5V
	RATED CURRENT	15A(Peak 20A)	5A	9.4A(Peak 16.7A)	5A	6.3A(Peak 11.1A)	5A	4.7A(Peak 8.4A)	5A
	CURRENT RANGE <small>Note.6</small>	0 ~ 15A (Peak 20A)	0 ~ 5A	0 ~ 9.4A (Peak 16.7A)	0 ~ 5A	0 ~ 6.3A (Peak 11.1A)	0 ~ 5A	0 ~ 4.7A (Peak 8.4A)	0 ~ 5A
	RATED POWER	205W		250.6W		251.8W		250.6W	
	RIPPLE & NOISE (max.) <small>Note.2</small>	120mVp-p	50mVp-p	150mVp-p	50mVp-p	200mVp-p	50mVp-p	200mVp-p	50mVp-p
	VOLTAGE ADJ. RANGE	10.8 ~ 13.2V	4.75 ~ 5.25V	21.6 ~ 26.4V	4.75 ~ 5.25V	32.4 ~ 39.6V	4.75 ~ 5.25V	43.2 ~ 52.8V	4.75 ~ 5.25V
	VOLTAGE TOLERANCE <small>Note.3</small>	± 3.0%	± 2.0%	± 2.0%	± 2.0%	± 2.0%	± 2.0%	± 2.0%	± 2.0%
	LINE REGULATION	± 0.5%	± 0.5%	± 0.5%	± 0.5%	± 0.5%	± 0.5%	± 0.5%	± 0.5%
	LOAD REGULATION	± 1.0%	± 2.0%	± 1.0%	± 2.0%	± 1.0%	± 2.0%	± 1.0%	± 2.0%
SETUP, RISE TIME	2500ms, 60ms/115VAC		1200ms, 60ms/230VAC						
HOLD UP TIME (Typ.)	30ms at full load								
INPUT	VOLTAGE RANGE <small>Note.5</small>	90 ~ 264VAC		127 ~ 370VDC					
	FREQUENCY RANGE	47 ~ 63Hz							
	POWER FACTOR	PF ≥ 0.92/230VAC		PF ≥ 0.97/115VAC at full load					
	EFFICIENCY(Typ.)	83%		86%		86%		86%	
	AC CURRENT (Typ.)	3A/115VAC		1.5A/230VAC					
	INRUSH CURRENT (Typ.)	COLD START 58A/230VAC							
LEAKAGE CURRENT	<3.5mA / 240VAC								
PROTECTION	OVERLOAD	CH1: 105 ~ 170% rated output power Normally work within 10 sec and then shut down, re-power on to recover Over 180% rated power or short circuit, constant current limiting within 10 sec and then shut down, re-power on to recover CH2: 101 ~ 150% rated output power Protection type : Hiccup mode, recovers automatically after fault condition is removed							
	OVER VOLTAGE	13.8 ~ 16.2V	5.5 ~ 6.75V	27.6 ~ 32.4V	5.5 ~ 6.75V	40 ~ 48V	5.5 ~ 6.75V	54 ~ 64.8V	5.5 ~ 6.75V
	OVER TEMPERATURE	Shut down o/p voltage(CH1), recovers automatically after temperature goes down							
FUNCTION	REMOTE CONTROL	CN52 : Open=CH1 & CH2 power on ; Short = CH1 power off, CH2 power on; when CH2 is malfunction, CH1 will be shut down							
ENVIRONMENT	WORKING TEMP.	-20 ~ +70°C (Refer to "Derating Curve")							
	WORKING HUMIDITY	20 ~ 90% RH non-condensing							
	STORAGE TEMP., HUMIDITY	-20 ~ +85°C, 10 ~ 95% RH							
	TEMP. COEFFICIENT	± 0.05%/°C (0 ~ 50°C)							
SAFETY & EMC (Note 4)	VIBRATION	10 ~ 500Hz, 2G 10min./1cycle, period for 60min each along X, Y, Z axes							
	SAFETY STANDARDS	UL62368-1, TUV EN62368-1, EAC TP TC 004 approved							
	WITHSTAND VOLTAGE	I/P-O/P:3KVAC		I/P-FG:2KVAC		O/P-FG:0.5KVAC			
	ISOLATION RESISTANCE	I/P-O/P, I/P-FG, O/P-FG:100M Ohms / 500VDC / 25°C / 70% RH							
	EMC EMISSION	Compliance to EN55032 (CISPR32) Class B, EN61000-3-2,-3, EAC TP TC 020							
OTHERS	EMC IMMUNITY	Compliance to EN61000-4-2,3,4,5,6,8,11, EN61000-6-2, heavy industry level, criteria A, EAC TP TC 020							
	MTBF	150.4K hrs min. MIL-HDBK-217F (25°C)							
	DIMENSION	222*95*40mm (L*W*H)							
NOTE	PACKING	0.74Kg; 18pcs/14.3Kg/0.98CUFT							
	NOTE	<ol style="list-style-type: none"> 1. All parameters NOT specially mentioned are measured at 230VAC input, rated load and 25°C of ambient temperature. 2. Ripple & noise are measured at 20MHz of bandwidth by using a 12" twisted pair-wire terminated with a 0.1uf & 47uf parallel capacitor. 3. Tolerance : includes set up tolerance, line regulation and load regulation. 4. The power supply is considered a component which will be installed into a final equipment. All the EMC tests are been executed by mounting the unit on a 360mm*360mm metal plate with 1mm of thickness. The final equipment must be re-confirmed that it still meets EMC directives. For guidance on how to perform these EMC tests, please refer to "EMI testing of component power supplies." 5. Derating may be needed under low input voltage. Please check the derating curve for more details. 6. Peak current should reduce to 150% of rated value if the input voltage <110VAC. 7. Heat Sink HS1,HS2,HS3 can not be shorted. 8. The ambient temperature derating of 3.5°C/1000m with fanless models and of 5°C/1000m with fan models for operating altitude higher than 2000m(6500ft). 							

250W Open Frame type Dual output power supply > PID-250

Mechanical Specification

Unit:mm

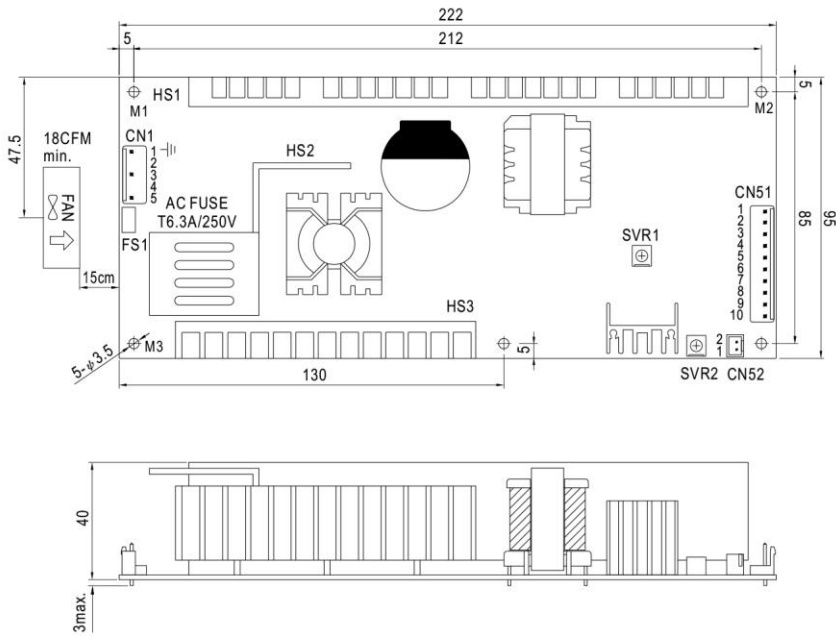

AC Input Connector (CN1) : JST B5P-VH or equivalent

Pin No.	Assignment	Mating Housing	Terminal
1	FG \perp	JST VHR or equivalent	JST SVH-21T-P1.1 or equivalent
2,4	No Pin		
3	AC/N		
5	AC/L		

\perp : Grounding Required

DC Output Connector (CN51) : JST B10P-VH or equivalent

Pin No.	Assignment	Mating Housing	Terminal
1,2,3	COM1	JST VHR or equivalent	JST SVH-21T-P1.1 or equivalent
4,5,6	V1		
7,8	COM2		
9,10	V2		

Remote ON/OFF Connector(CN52):JST B2B-XH or equivalent

Pin No.	Status	Mating Housing	Terminal
PIN1,2 (Short)	V1: OFF V2: ON	JST XHP or equivalent	JST SXH-001T-P0.6 or equivalent
PIN1,2 (Open)	V1: ON V2: ON		

SVR1	For CH1
SVR2	For CH2



- 1.HS1,HS2,HS3 cannot be shorted.
- 2.CN1:Pin1 is safety ground. For better EMC performance,Please secure an electrical connection between M1,M2,M3,and chassis grounding.

Block Diagram

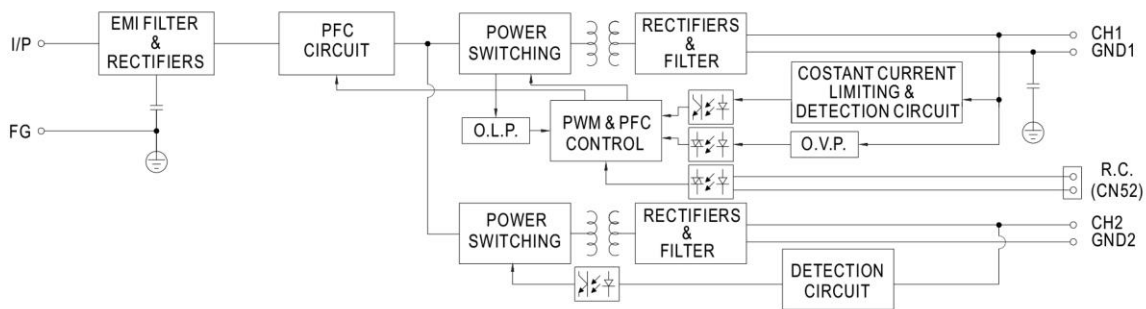

PFC fosc : 100KHz
 PWM fosc : 100KHz

Derating Curve

Output Derating VS Input Voltage

