



E-Star Power Development Co., Ltd. (E-STAR)
 1F., No.40, Juren Ln., Sec. 2, Sanmin Rd., Banciao Dist., New Taipei City
 22069, Taiwan (R.O.C.)
 Phone : 886-2-2957 5580 Fax : 886-2-2957 7473

55W Enclosed power supply < ADS-55



■ Features :

- Universal AC input / Full range
- Protections: Short circuit / Overload / Over voltage
- Cooling by free air convection
- 100% full load burn-in test
- Fixed switching frequency at 45KHz
- 2 years warranty



SPECIFICATION

MODEL		ADS-5512		ADS-5524	
OUTPUT	OUTPUT NUMBER	CH1	CH2	CH1	CH2
	DC VOLTAGE	12V	5V	24V	5V
	RATED CURRENT	3A	3A	2A	2A
	CURRENT RANGE	0 ~ 4A	0 ~ 4A	0 ~ 2.5A	0 ~ 4A
	RATED POWER	51W		58W	
	RIPPLE & NOISE (max.) Note.2	100mVp-p		100mVp-p	100mVp-p
	VOLTAGE ADJ. RANGE	CH1:10.8 ~ 13.2V		CH1:21.6 ~ 26.4V	
	VOLTAGE TOLERANCE Note.3	±1.0%	±3.0%	±1.0%	±3.0%
	LINE REGULATION	±0.5%	±0.5%	±1.0%	±0.5%
	LOAD REGULATION	±0.5%	±0.5%	±1.0%	±0.5%
	SETUP, RISE TIME	1400ms, 50ms/230VAC		3300ms, 50ms/115VAC at full load	
HOLD UP TIME (Typ.)	80ms/230VAC	16ms/115VAC at full load			
INPUT	VOLTAGE RANGE	88 ~ 264VAC	124 ~ 370VDC		
	FREQUENCY RANGE	47 ~ 63Hz			
	EFFICIENCY (Typ.)	76%		79%	
	AC CURRENT (Typ.)	1.6A/115VAC	1A/230VAC		
	INRUSH CURRENT (Typ.)	COLD START 20A/115VAC		40A/230VAC	
LEAKAGE CURRENT	<1mA / 240VAC				
PROTECTION	OVERLOAD	105 ~ 150% rated output power Protection type : Hiccup mode, recovers automatically after fault condition is removed			
	OVER VOLTAGE	CH1:13.8 ~ 16.2V		CH1:27.6 ~ 32.4V Protection type : Hiccup mode, recovers automatically after fault condition is removed	
ENVIRONMENT	WORKING TEMP.	-10 ~ +60°C (Refer to "Derating Curve")			
	WORKING HUMIDITY	20 ~ 90% RH non-condensing			
	STORAGE TEMP., HUMIDITY	-20 ~ +85°C, 10 ~ 95% RH			
	TEMP. COEFFICIENT	±0.03%/°C (0~50°C) on CH1 output			
VIBRATION	10 ~ 500Hz, 2G 10min./1cycle, 60min. each along X, Y, Z axes				
SAFETY & EMC (Note 4)	SAFETY STANDARDS	UL62368-1, TUV EN62368-1, EAC TP TC 004 approved			
	WITHSTAND VOLTAGE	I/P-O/P:3KVAC I/P-FG:2KVAC O/P-FG:0.5KVAC			
	ISOLATION RESISTANCE	I/P-O/P, I/P-FG, O/P-FG:100M Ohms / 500VDC / 25°C/ 70% RH			
	EMC EMISSION	Compliance to EN55032 (CISPR32) Class B, EN61000-3-2,-3, EAC TP TC 020			
	EMC IMMUNITY	Compliance to EN61000-4-2,3,4,5,6,8,11, EN55024, light industry level, criteria A, EAC TP TC 020			
OTHERS	MTBF	276.3K hrs min. MIL-HDBK-217F (25°C)			
	DIMENSION	159*97*38mm (L*W*H)			
	PACKING	0.57Kg; 24pcs/13.7Kg/0.83CUFT			
NOTE	1. All parameters NOT specially mentioned are measured at 230VAC input, rated load and 25°C of ambient temperature. 2. Ripple & noise are measured at 20MHz of bandwidth by using a 12" twisted pair-wire terminated with a 0.1uf & 47uf parallel capacitor. 3. Tolerance : includes set up tolerance, line regulation and load regulation. 4. The power supply is considered a component which will be installed into a final equipment. All the EMC tests are been executed by mounting the unit on a 360mm*360mm metal plate with 1mm of thickness. The final equipment must be re-confirmed that it still meets EMC directives. For guidance on how to perform these EMC tests, please refer to "EMI testing of component power supplies." 5. The ambient temperature derating of 3.5°C/1000m with fanless models and of 5°C/1000m with fan models for operating altitude higher than 2000m(6500ft).				



E-Star Power Development Co., Ltd. (E-STAR)

1F., No.40, Juren Ln., Sec. 2, Sanmin Rd., Banciao Dist., New Taipei City 22069, Taiwan (R.O.C.)

Phone : 886-2-2957 5580 Fax : 886-2-2957 7473

55W Enclosed power supply < ADS-55

Mechanical Specification

Case No. 901 Unit:mm

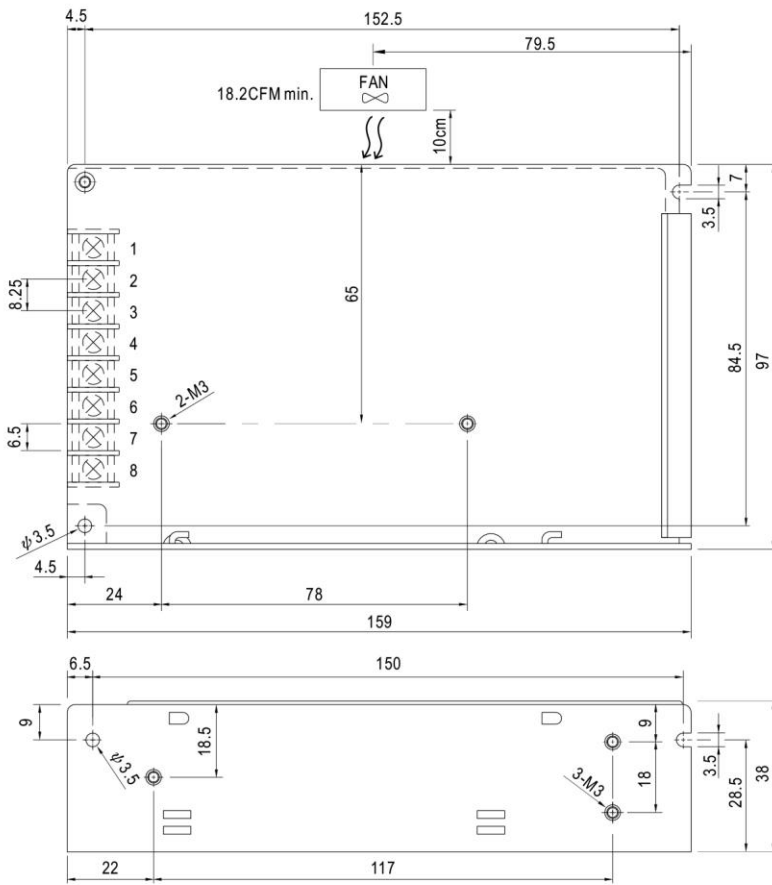

Terminal Pin No. Assignment :

Pin No.	Assignment	Pin No.	Assignment
1	AC/L	5	DC OUTPUT +V
2	AC/N	6	NC
3	FG	8	DC/DC OUTPUT +5V
4,7	DC OUTPUT COM		

Block Diagram

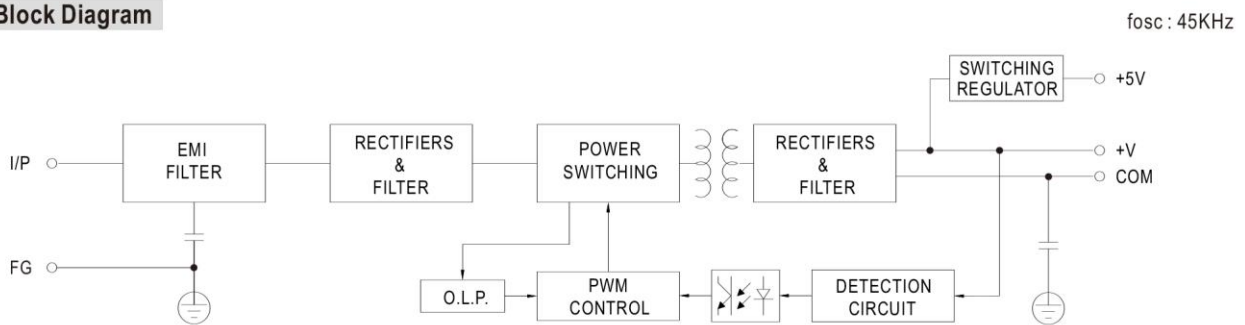

Derating Curve

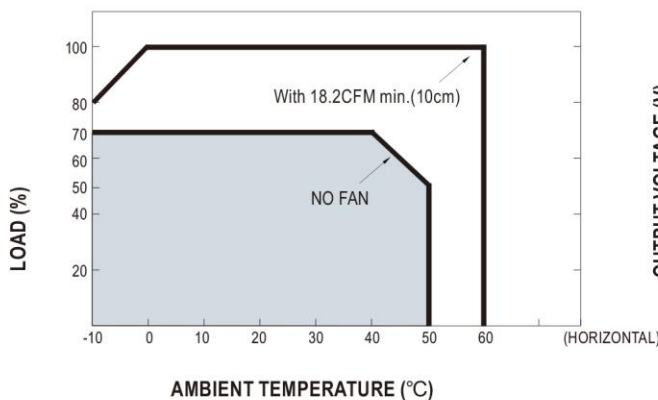

Static Characteristics (5512)

