



**60W Open Frame Medical power supply < RPT-60**



■ Features :

- 4"×2" miniature size
- Universal AC input / Full range
- Low leakage current <100μA
- Protections: Short circuit / Overload / Over voltage
- Cooling by free air convection
- Medical safety approved (2 x MOPP between primary to secondary)
- UL60950-1/IEC60950-1/EN60950-1 ITE safety approved
- Fixed switch frequency at 100KHz
- Suitable for BF application with appropriate system consideration
- 3 years warranty



**SPECIFICATION**

MODEL		RPT-60A			RPT-60B			RPT-60C		
OUTPUT	OUTPUT NUMBER	CH1	CH2	CH3	CH1	CH2	CH3	CH1	CH2	CH3
	DC VOLTAGE	5V	12V	-5V	5V	12V	-12V	5V	15V	-15V
	RATED CURRENT	4A	2A	0.5A	4A	2A	0.5A	4A	1.5A	0.5A
	CURRENT RANGE	0.5 ~ 4.4A	0.1 ~ 2.2A	0.1 ~ 0.55A	0.5 ~ 4.4A	0.1 ~ 2.2A	0.1 ~ 0.55A	0.5 ~ 4.4A	0.1 ~ 1.65A	0.1 ~ 0.55A
	RATED POWER	46.5W			50W			50W		
	PEAK LOAD(10sec.) Note.4	51.15W			55W			55W		
	RIPPLE & NOISE (max.) Note.2	80mVp-p	80mVp-p	80mVp-p	80mVp-p	80mVp-p	100mVp-p	80mVp-p	100mVp-p	150mVp-p
	VOLTAGE TOLERANCE Note.3	+3,-2%	±6.0%	+9,-8%	+3,-2%	±6.0%	+10,-6%	+3,-2%	±6.0%	±8.0%
	LINE REGULATION	±0.5%	±1.0%	±1.0%	±0.5%	±1.0%	±2.0%	±0.5%	±2.0%	±2.0%
	LOAD REGULATION	±1.5%	±2.0%	+5,-7%	±1.5%	±2.0%	±5.0%	±1.5%	±3.0%	±4.0%
SETUP, RISE TIME	300ms, 15ms/230VAC			300ms, 15ms/115VAC at full load						
HOLD UP TIME (Typ.)	70ms/230VAC		15ms/115VAC at full load							
INPUT	VOLTAGE RANGE	90 ~ 264VAC		127 ~ 370VDC						
	FREQUENCY RANGE	47 ~ 63Hz								
	EFFICIENCY (Typ.)	77%			78%			79%		
	AC CURRENT (Typ.)	1.1A/115VAC		0.7A/230VAC						
	INRUSH CURRENT (Typ.)	COLD START 60A/230VAC		30A/115VAC						
LEAKAGE CURRENT Note.8	Earth leakage current < 150μA/264VAC , Touch current < 100μA/264VAC									
PROTECTION	OVERLOAD	115 ~ 150% rated output power Protection type : Hiccup mode, recovers automatically after fault condition is removed								
	OVER VOLTAGE	CH1: 5.75 ~ 6.75V Protection type : Shut down o/p voltage, re-power on to recover								
ENVIRONMENT	WORKING TEMP.	-20 ~ +65°C (Refer to "Derating Curve")								
	WORKING HUMIDITY	20 ~ 90% RH non-condensing								
	STORAGE TEMP., HUMIDITY	-40 ~ +85°C, 10 ~ 95% RH								
	TEMP. COEFFICIENT	±0.03%/°C (0 ~ 45°C)								
SAFETY & EMC (Note 5)	VIBRATION	10 ~ 500Hz, 2G 10min./1cycle, period for 60min. each along X, Y, Z axes								
	SAFETY STANDARDS	UL60950-1, TUV EN60950-1, ANSI/AAMI ES60601-1, TUV EN60601-1, IEC60601-1 approved								
	ISOLATION LEVEL	Primary-Secondary: 2xMOPP, Primary-Earth:1xMOPP, Secondary-Earth:1xMOPP								
	WITHSTAND VOLTAGE	I/P-O/P:4KVAC I/P-FG:2KVAC O/P-FG:1.5KVAC								
	ISOLATION RESISTANCE	I/P-O/P, I/P-FG, O/P-FG:100M Ohms / 500VDC / 25°C / 70% RH								
	EMC EMISSION	Compliance to EN55011(CISPR11),EN55022 (CISPR22) Class B, EN61000-3-2,-3								
OTHERS	EMC IMMUNITY	Compliance to EN61000-4-2,3,4,5,6,8,11, EN55024, EN60601-1-2, EN61204-3, medical level, criteria A								
	MTBF	677.8K hrs min. MIL-HDBK-217F (25°C)								
	DIMENSION	101.6*50.8*29mm (L*W*H)								
NOTE	PACKING	0.15Kg; 96pcs/15.4Kg/0.89CUFT								
		<ol style="list-style-type: none"> <li>All parameters NOT specially mentioned are measured at 230VAC input, rated load and 25°C of ambient temperature.</li> <li>Ripple &amp; noise are measured at 20MHz of bandwidth by using a 12" twisted pair-wire terminated with a 0.1uf &amp; 47uf parallel capacitor.</li> <li>Tolerance : includes set up tolerance, line regulation and load regulation.</li> <li>33% Duty cycle maximum within every 30 seconds. Average output power should not exceed the rated power.</li> <li>The power supply is considered a component which will be installed into a final equipment. All the EMC tests are been executed by mounting the unit on a 360mm*360mm metal plate with 1mm of thickness. The final equipment must be re-confirmed that it still meets EMC directives. For guidance on how to perform these EMC tests, please refer to "EMI testing of component power supplies."</li> <li>Length of set up time is measured at cold first start. Turning ON/OFF the power supply may lead to increase of the set up time.</li> <li>Heat Sink HS1,HS2 can not be shorted.</li> <li>Touch current was measured from primary input to DC output.</li> </ol>								



**60W Open Frame Medical power supply < RPT-60**



■ Features :

- 4"×2" miniature size
- Universal AC input / Full range
- Low leakage current <100μA
- Protections: Short circuit / Overload / Over voltage
- Cooling by free air convection
- Medical safety approved (2 x MOPP between primary to secondary)
- UL60950-1/IEC60950-1/EN60950-1 ITE safety approved
- Fixed switch frequency at 100KHz
- Suitable for BF application with appropriate system consideration
- 3 years warranty



**SPECIFICATION**

MODEL		RPT-60D			RPT-6003		
OUTPUT	OUTPUT NUMBER	CH1	CH2	CH3	CH1	CH2	CH3
	DC VOLTAGE	5V	24V	12V	3.3V	5V	12V
	RATED CURRENT	3.5A	1A	0.5A	5A	3A	0.7A
	CURRENT RANGE	0.5 ~ 3.85A	0.1 ~ 1.1A	0.1 ~ 0.55A	0.5 ~ 5.5A	0.3 ~ 3.3A	0.1 ~ 0.77A
	RATED POWER	47.5W			39.9W		
	PEAK LOAD(10sec.) Note.4	52.25W			43.89W		
	RIPPLE & NOISE (max.) Note.2	80mVp-p	150mVp-p	80mVp-p	80mVp-p	80mVp-p	80mVp-p
	VOLTAGE TOLERANCE Note.3	+3,-2%	±6.0%	±8.0%	+3,-2%	±8.0%	+10,-6%
	LINE REGULATION	±0.5%	±2.0%	±2.0%	±0.5%	±1.0%	±2.0%
	LOAD REGULATION	±1.5%	±3.0%	±4.0%	±1.5%	±2.0%	+5.5,-5%
SETUP, RISE TIME	300ms, 15ms/230VAC 300ms, 15ms/115VAC at full load						
HOLD UP TIME (Typ.)	70ms/230VAC 15ms/115VAC at full load						
INPUT	VOLTAGE RANGE	90 ~ 264VAC		127 ~ 370VDC			
	FREQUENCY RANGE	47 ~ 63Hz					
	EFFICIENCY (Typ.)	79%			75%		
	AC CURRENT (Typ.)	1.1A/115VAC		0.7A/230VAC			
	INRUSH CURRENT (Typ.)	COLD START 60A/230VAC		30A/115VAC			
LEAKAGE CURRENT Note.8	Earth leakage current < 150μA/264VAC , Touch current < 100μA/264VAC						
PROTECTION	OVERLOAD	115 ~ 150% rated output power Protection type : Hiccup mode, recovers automatically after fault condition is removed					
	OVER VOLTAGE	CH1: 5.75 ~ 6.75V			CH1: 3.8 ~ 4.45V		
ENVIRONMENT	WORKING TEMP.	-20 ~ +65°C (Refer to "Derating Curve")					
	WORKING HUMIDITY	20 ~ 90% RH non-condensing					
	STORAGE TEMP., HUMIDITY	-40 ~ +85°C, 10 ~ 95% RH					
	TEMP. COEFFICIENT	±0.03%/°C (0 ~ 45°C)					
	VIBRATION	10 ~ 500Hz, 2G 10min./1cycle, period for 60min. each along X, Y, Z axes					
SAFETY & EMC (Note 5)	SAFETY STANDARDS	UL60950-1, TUV EN60950-1, ANSI/AAMI ES60601-1, TUV EN60601-1, IEC60601-1 approved					
	ISOLATION LEVEL	Primary-Secondary: 2xMOPP, Primary-Earth:1xMOPP, Secondary-Earth:1xMOPP					
	WITHSTAND VOLTAGE	I/P-O/P:4KVAC I/P-FG:2KVAC O/P-FG:1.5KVAC					
	ISOLATION RESISTANCE	I/P-O/P, I/P-FG, O/P-FG:100M Ohms / 500VDC / 25 / 70% RH					
	EMC EMISSION	Compliance to EN55011(CISPR11),EN55022 (CISPR22) Class B, EN61000-3-2,-3					
EMC IMMUNITY	Compliance to EN61000-4-2,3,4,5,6,8,11, EN55024, EN60601-1-2, EN61204-3, medical level, criteria A						
OTHERS	MTBF	677.8K hrs min. MIL-HDBK-217F (25°C)					
	DIMENSION	101.6*50.8*29mm (L*W*H)					
	PACKING	0.15Kg; 96pcs/15.4Kg/0.89CUFT					
NOTE	<ol style="list-style-type: none"> <li>1. All parameters NOT specially mentioned are measured at 230VAC input, rated load and 25°C of ambient temperature.</li> <li>2. Ripple &amp; noise are measured at 20MHz of bandwidth by using a 12" twisted pair-wire terminated with a 0.1uf &amp; 47uf parallel capacitor.</li> <li>3. Tolerance : includes set up tolerance, line regulation and load regulation.</li> <li>4. 33% Duty cycle maximum within every 30 seconds. Average output power should not exceed the rated power.</li> <li>5. The power supply is considered a component which will be installed into a final equipment. All the EMC tests are been executed by mounting the unit on a 360mm*360mm metal plate with 1mm of thickness. The final equipment must be re-confirmed that it still meets EMC directives. For guidance on how to perform these EMC tests, please refer to "EMI testing of component power supplies."</li> <li>6. Length of set up time is measured at cold first start. Turning ON/OFF the power supply may lead to increase of the set up time.</li> <li>7. Heat Sink HS1,HS2 can not be shorted.</li> <li>8. Touch current was measured from primary input to DC output.</li> </ol>						

**60W Open Frame Medical power supply < RPT-60**

**Mechanical Specification**

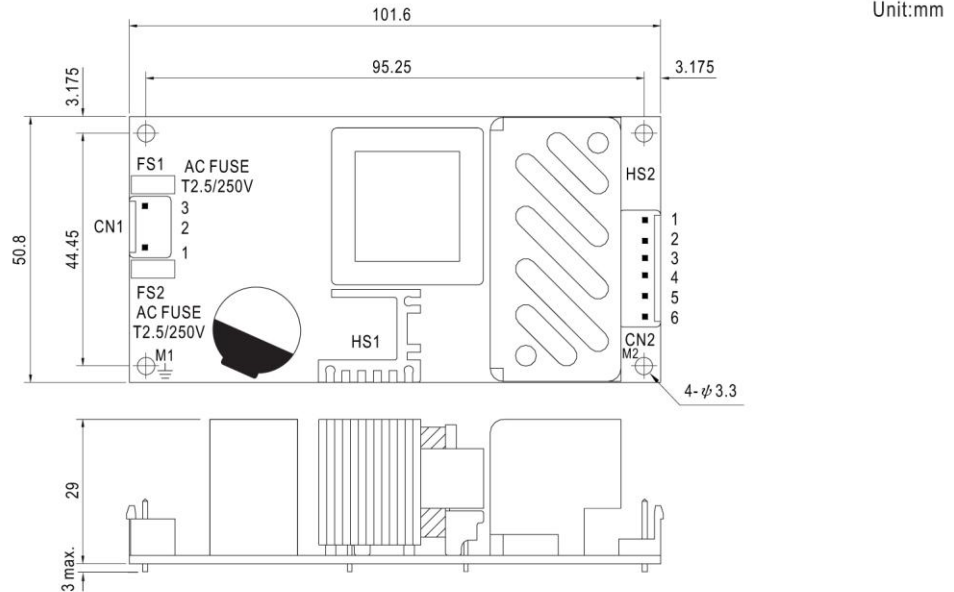

AC Input Connector (CN1) : JST B3P-VH or equivalent

Pin No.	Assignment	Mating Housing	Terminal
1	AC/N	JST VHR or equivalent	JST SVH-21T-P1.1 or equivalent
2	No Pin		
3	AC/L		

⊥ : Grounding Required

- ⚠ 1.HS1,HS2 cannot be shorted.
- 2.M1 is safety ground. For better EMC performance, Please secure an electrical connection between M1,M2 and chassis grounding.

DC Output Connector (CN2) : JST B6P-VH or equivalent

Pin No.	Assignment	Mating Housing	Terminal
1,2	V1	JST VHR or equivalent	JST SVH-21T-P1.1 or equivalent
3,4	COM		
5	V2		
6	V3		

**Block Diagram**

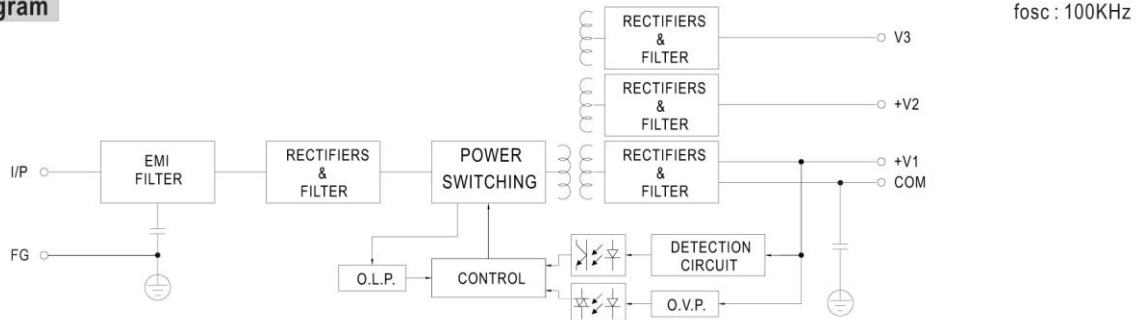

**Derating Curve**

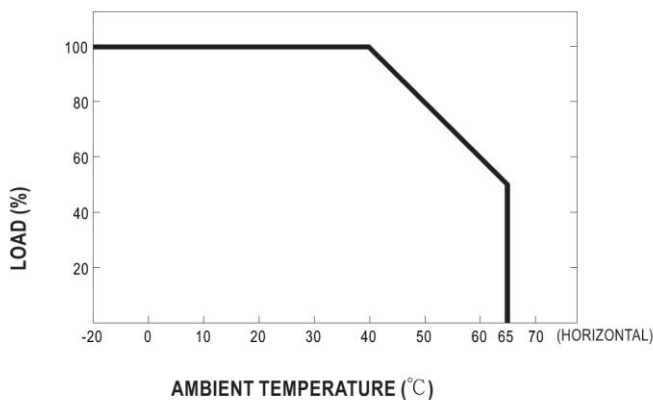

**Output Derating VS Input Voltage**

