



155W Battery Charger Power supply > ADD-155



■ Features :

- Universal AC input / Full range
- Built-in active PFC function
- Protections: Short circuit / Overload / Over voltage
- Battery low/battery polarity protections
- Cooling by free air convection
- 100% full load burn-in test
- Fixed switching frequency at PFC 67KHz, PWM 134KHz
- 2 years warranty



SPECIFICATION

MODEL		ADD-155A			ADD-155B			ADD-155C			
OUTPUT	OUTPUT NUMBER	CH1	CH2	CH3	CH1	CH2	CH3	CH1	CH2	CH3	
	DC VOLTAGE	13.8V	5V	13.3V	27.6V	5V	27.1V	54V	5V	53.5V	
	RATED CURRENT	9.5A	3A	0.5A	4.5A	3A	0.5A	2.3A	3A	0.2A	
	CURRENT RANGE	0 ~ 10.5A	0 ~ 3A	-----	0 ~ 5A	0 ~ 3A	-----	0 ~ 2.5A	0 ~ 3A	-----	
	RATED POWER	152.75W			152.75W			149.9W			
	RIPPLE & NOISE (max.) Note.2	150mVp-p	100mVp-p	-----	200mVp-p	100mVp-p	-----	240mVp-p	100mVp-p	-----	
	VOLTAGE ADJ. RANGE	CH1: 12 ~ 14.5V			CH1: 24 ~ 29V			CH1: 48 ~ 58V			
	VOLTAGE TOLERANCE Note.3	±2.0%	±3.0%	-----	±1.0%	±3.0%	-----	±1.0%	±5.0%	-----	
	LINE REGULATION	±1.0%	±0.5%	-----	±1.0%	±0.5%	-----	±1.0%	±0.5%	-----	
	LOAD REGULATION	±1.0%	±2.0%	-----	±1.0%	±2.0%	-----	±1.0%	±2.0%	-----	
SETUP, RISE TIME	1000ms, 90ms/230VAC			2000ms, 90ms/115VAC at full load							
HOLD UP TIME (Typ.)	24ms/230VAC		20ms/115VAC at full load								
INPUT	VOLTAGE RANGE	88 ~ 264VAC		124 ~ 370VDC							
	FREQUENCY RANGE	47 ~ 63Hz									
	POWER FACTOR (Typ.)	PF>0.92 at full load									
	EFFICIENCY (Typ.)	78%			81%			81%			
	AC CURRENT (Typ.)	2.5A/115VAC		1.5A/230VAC							
	INRUSH CURRENT (Typ.)	COLD START 23A/115VAC		45A/230VAC							
LEAKAGE CURRENT	<1mA / 240VAC										
PROTECTION	OVERLOAD	CH1,CH2:105 ~ 135% CH3:0.51 ~ 0.9A rated output power									
		Protection type : AC Charging Mode : Constant current limiting, recovers automatically after fault condition is removed									
		UPS Mode : Protected by internal fuse									
	OVER VOLTAGE	CH1:15.87 ~ 18.63V		CH1:31.74 ~ 37.26V		CH1:62.1 ~ 72.9V					
		Protection type : Shut down o/p voltage, re-power on to recover									
	BATTERY LOW	10V ± 0.8V		19.5V(+1.5V,-1V)		39V ± 2V					
ENVIRONMENT	WORKING TEMP.	-10 ~ +60°C (Refer to "Derating Curve")									
	WORKING HUMIDITY	20 ~ 90% RH non-condensing									
	STORAGE TEMP., HUMIDITY	-20 ~ +85°C, 10 ~ 95% RH									
	TEMP. COEFFICIENT	±0.03%/°C (0 ~ 50°C) on +5V output									
	VIBRATION	10 ~ 500Hz, 2G 10min./1cycle, 60min. each along X, Y, Z axes									
SAFETY & EMC (Note 4)	SAFETY STANDARDS	UL62368-1, TUV EN62368-1, EAC TP TC 004 approved									
	WITHSTAND VOLTAGE	I/P-O/P:3KVAC I/P-FG:2KVAC O/P-FG:0.5KVAC									
	ISOLATION RESISTANCE	I/P-O/P, I/P-FG, O/P-FG:100M Ohms / 500VDC / 25°C / 70% RH									
	EMC EMISSION	Compliance to EN55032 (CISPR32) Class B, EN61000-3-2,-3, EAC TP TC 020									
	EMC IMMUNITY	Compliance to EN61000-4-2,3,4,5,6,8,11, EN55024, light industry level, criteria A, EAC TP TC 020									
OTHERS	MTBF	164.2K hrs min. MIL-HDBK-217F (25°C)									
	DIMENSION	199*110*50mm (L*W*H)									
	PACKING	1Kg; 16pcs/16Kg/0.95CUFT									
NOTE	<ol style="list-style-type: none"> 1. All parameters NOT specially mentioned are measured at 230VAC input, rated load and 25°C of ambient temperature. 2. Ripple & noise are measured at 20MHz of bandwidth by using a 12" twisted pair-wire terminated with a 0.1uf & 47uf parallel capacitor. 3. Tolerance : includes set up tolerance, line regulation and load regulation. 4. The power supply is considered a component which will be installed into a final equipment. All the EMC tests are been executed by mounting the unit on a 360mm*360mm metal plate with 1mm of thickness. The final equipment must be re-confirmed that it still meets EMC directives. For guidance on how to perform these EMC tests, please refer to "EMI testing of component power supplies." 5. The ambient temperature derating of 3.5°C/1000m with fanless models and of 5°C/1000m with fan models for operating altitude higher than 2000m(6500ft). 										



155W Battery Charger Power supply > ADD-155

Mechanical Specification

Case No. 906B Unit:mm

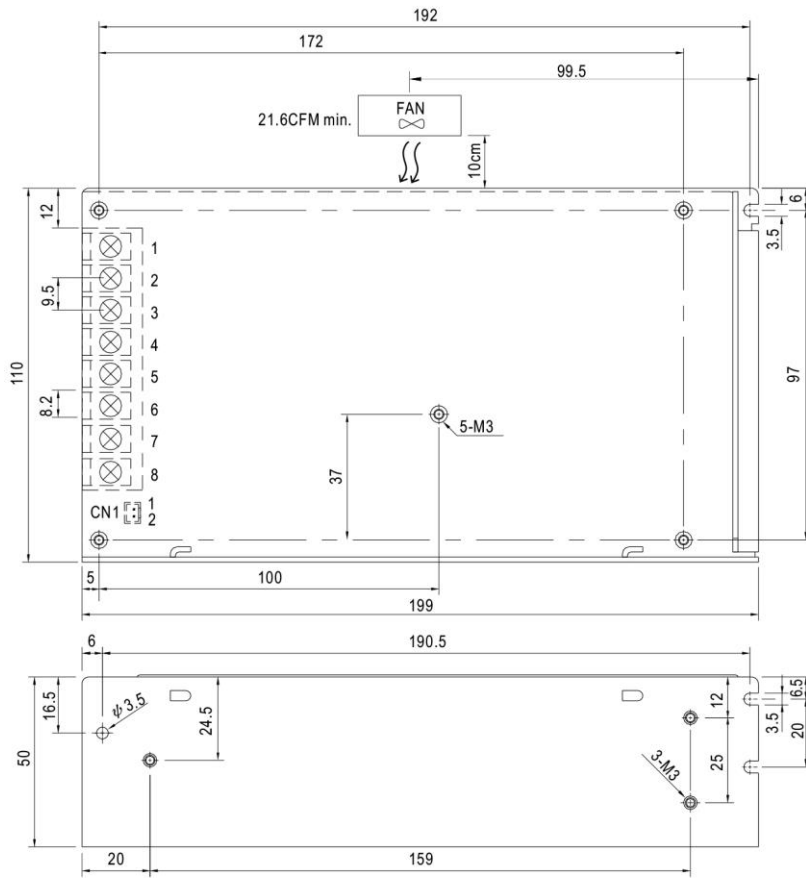

Terminal Pin No. Assignment

Pin No.	Assignment	Pin No.	Assignment
1	AC/L	5	BAT. +
2	AC/N	6	BAT. -/COM
3	FG \perp	7	DC OUTPUT COM
4	+5V	8	DC OUTPUT +V

CN1 Pin No. Assignment : JST B2B-XH or equivalent

Pin No.	Assignment	Mating Housing	Terminal
1	RESET SW	JST XHP or equivalent	JST SXH-001T-P0.6
2			or equivalent

Block Diagram

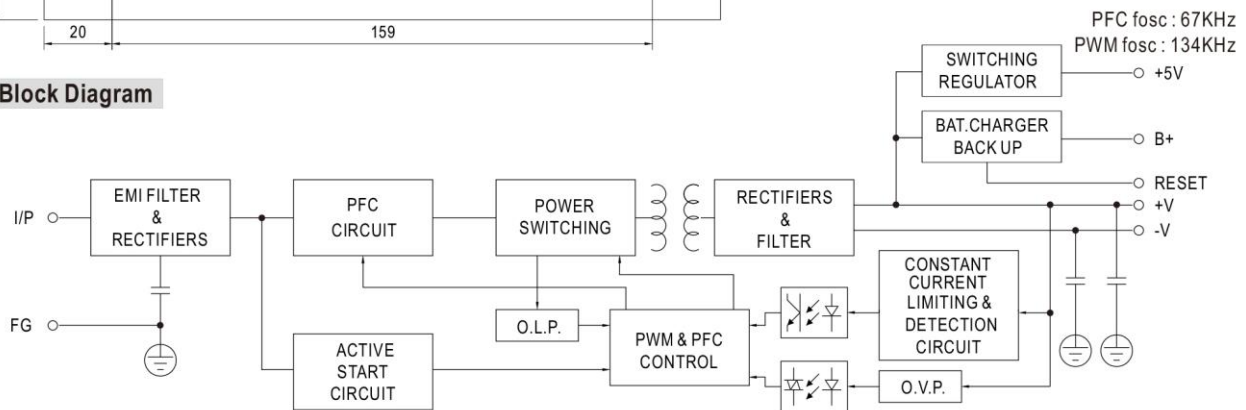

Derating Curve

Output Derating VS Input Voltage (A)

